

HAFCO WOODMASTER

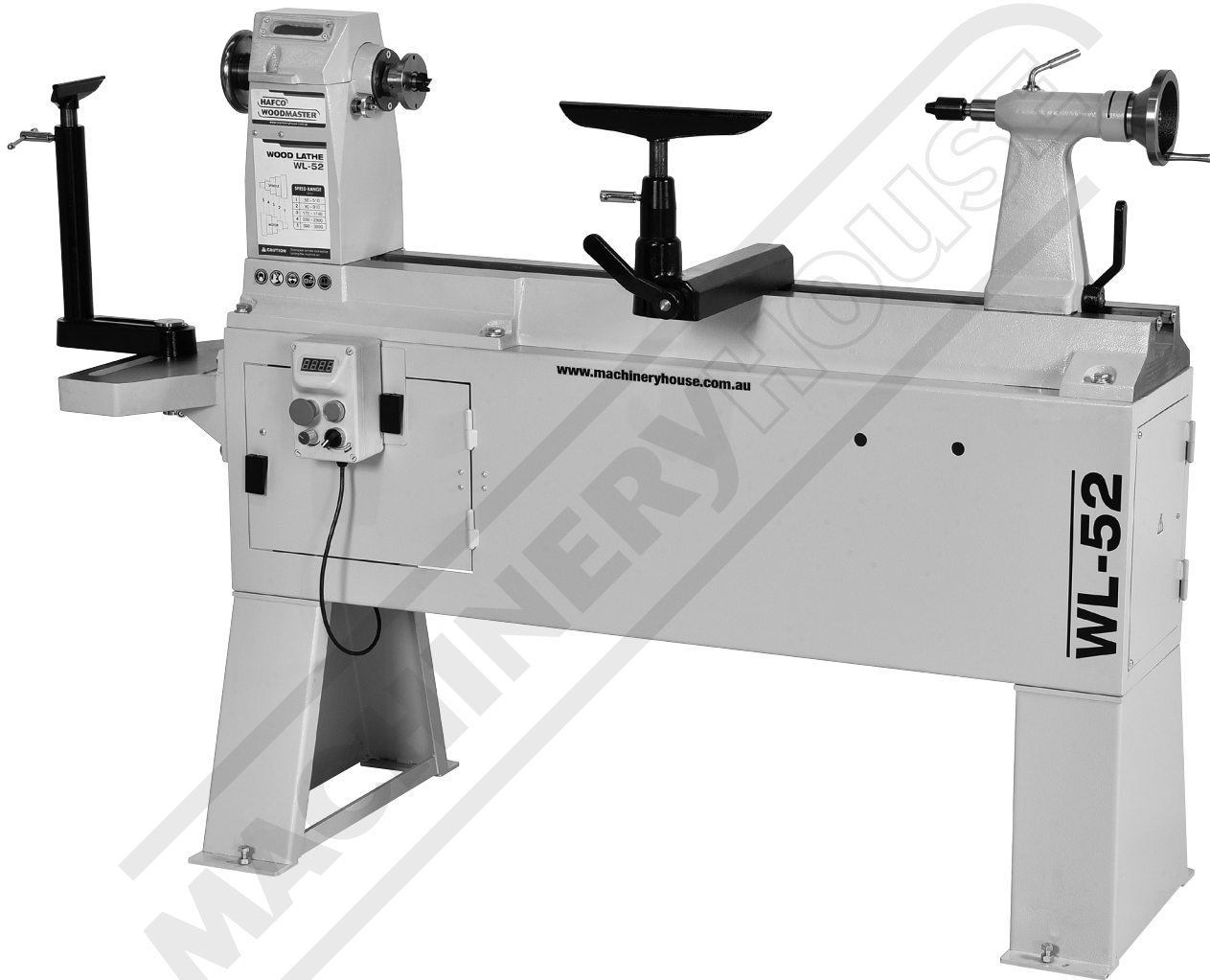

Edition : 1.0
Date: (12/24)

Instruction Manual

HEAVY DUTY - WOOD LATHE WL-52

Order Code: (W686)

MACHINE DETAILS

MACHINE	WOOD LATHE
MODEL NO.	WL-52
SERIAL NO.	
DATE OF MANF.	

IMPORTED BY

AUSTRALIA



www.machineryhouse.com.au

NEW ZEALAND



www.machineryhouse.co.nz

NOTE:

This manual is for your reference. At the time of the compiling of this manual every effort to be exact with the instructions, specifications, drawings, and photographs of the machine was taken. Owing to the continuous improvement of the HAFCO WOODMASTER machine, changes may be made at any time without obligation or notice. Please ensure the local voltage is the same as listed on the specification plate before operating any electric machine.

SAFETY SYMBOLS

The purpose of safety symbols is to attract your attention to possible hazardous conditions

WARNING Indicates a potentially hazardous situation causing injury or death

CAUTION Indicates an alert against unsafe practices.

Note: Used to alert the user to useful information



NOTE:

In order to see the type and model of the machine, please see the specification plate. Usually found on the back of the machine. See example (Fig.1)

HAFCO
WOODMASTER

PRODUCT SPECIFICATIONS

Model: WL-52

Capacity: Ø520mm x 910mm	Voltage: 240V/50Hz
Nett Weight: 206kg	Motor: 1.5kW
MFG Date:	FLC:6.8A

Serial No:

Imported by www.machineryhouse.com.au Made in China
www.machineryhouse.co.nz

FIG.1

CONTENTS:

1. GENERAL MACHINE INFORMATION	
1.1 Specifications.....	4
1.2 Standard Equipment.....	4
1.3 Identification.....	5
2. SAFETY	
2.1 General Metalworking Machine Safety.....	6
2.2 Specific Safety For Wood Lathe.....	9
3. POWER SUPPLY	
3.1 Electrical Requirements.....	10
3.2 Full Load Current.....	10
4. SETUP	
4.1 Unpacking.....	11
4.2 Clean Up.....	11
4.3 Site Preparation.....	11
4.4 Lifting Instructions.....	11
4.5 Anchoring To The Floor.....	12
4.6 Machine Leveling.....	12
4.7 Assembly.....	13
4.8 Test Run.....	17
5. OPERATION	
5.1 Controls.....	17
5.2 Changing Speed Ranges.....	18
5.3 Lathe Parts & Controls.....	19
5.4 Wood-turning.....	22
5.5 Troubleshooting.....	23
6. MAINTENANCE	
6.1 Schedule.....	24
6.2 Lubrication and Cleaning.....	25
6.3 Belt Adjustment.....	25
Spare Parts.....	26
Risk Assessment Sheets.....	29

1.1 SPECIFICATION

Order Code	W686
MODEL	WL-52
Distance Between Centres	910 mm
Swing Over Bed	520 mm
Rear Turning Capacity	760 mm
Swing Over Toolrest Base	416mm
Headstock Taper	2 MT
Hole Through Spindle	15mm
Tailstock Taper	2 MT
Tailstock Spindle Travel	100 mm
Spindle Speeds	50 - 3890 RPM
Spindle Thread (Australia)	30 mm x 3.5P
Spindle Lock	Standard
Motor Connect to Single Phase Power	1.5 kw Inverter Motor
Switch	Mag-Con with Remote STOP / START Station
Indexing - 24 Divisions	Standard
Floor Space	1450mm long x 580mm wide
Packed Weight - with stand	270 kg

1.2 STANDARD EQUIPMENT

Face Plate 82 mm Right Hand	1	Centre Knockout Bar	1
Face Plate Spanner	2	Handwheel Brake	1
Spur Drive Centre 25 mm	1	Indexing/Spindle Lock Pin	1
Revolving Cup Centre	1	Allen Key 3 mm	1
Toolrest 300 mm	1	Allen Key 4 mm	1
Toolrest 150 mm	1	Motor and Switch	1
Cam-lock Toolrest Bracket	1	Instruction Manual	1

1.3 IDENTIFICATION

Become familiar with the names and locations of the controls and features shown below to better understand the instructions in this manual.

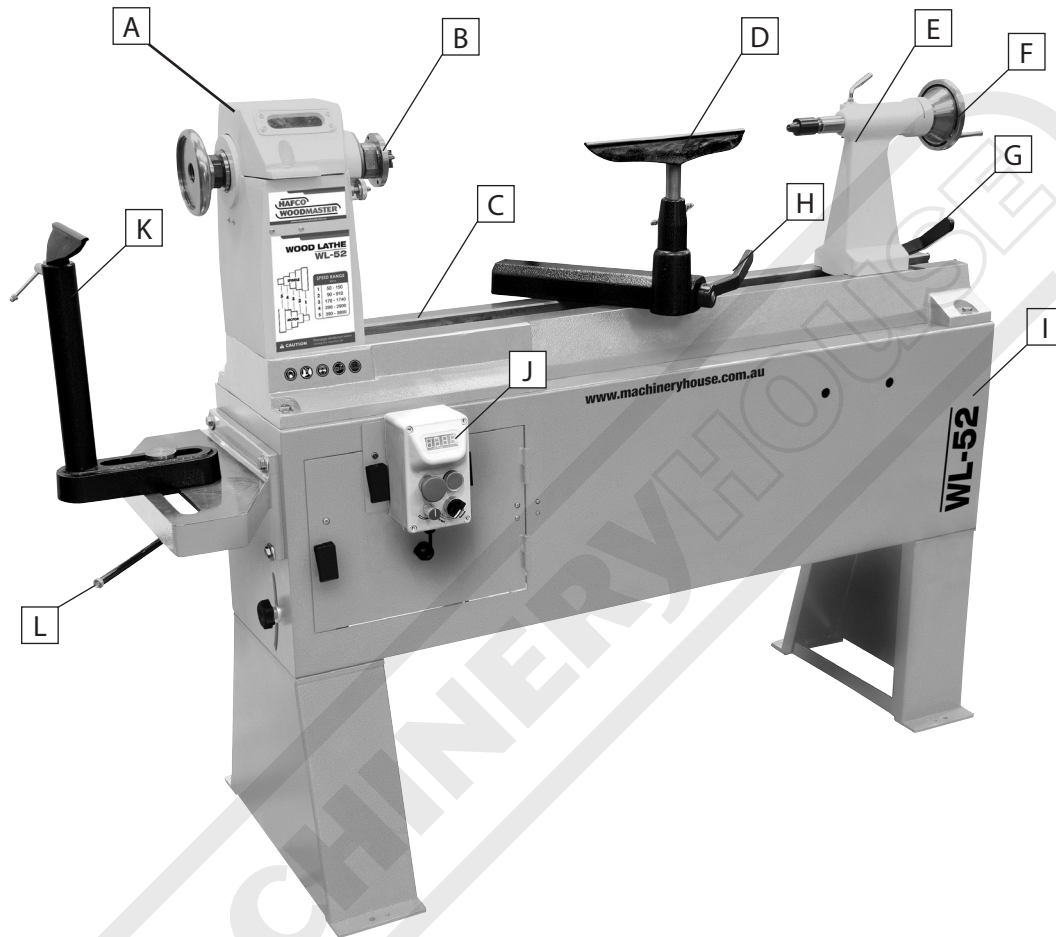

A	Headstock	G	Tailstock Lock
B	Spindle	H	Toolrest Lock
C	Bed	I	Stand
D	Toolrest	J	Electrical Switch Box
E	Tailstock	K	Outward Toolrest
F	Tailstock Handle	L	Outward Toolrest Lock

2.1 GENERAL WOODWORKING MACHINE SAFE PRACTICES

DO NOT use this machine unless you have read this manual or have been instructed in the safe use and operation of this machine.



WARNING

This manual provides safety instructions on the proper setup, operation, maintenance, and service of this machine. Save this manual, refer to it often, and use it to instruct other operators. Failure to read, understand and follow the instructions in this manual may result in fire or serious personal injury, including amputation, electrocution, or death.

The owner of this machine is solely responsible for its safe use. This responsibility includes, but is not limited to proper installation in a safe environment, personnel training and authorization to use, proper inspection and maintenance, manual availability and comprehension, of the application of the safety devices, integrity, and the use of personal protective equipment.

The manufacturer will not be held liable for injury or property damage from negligence, improper training, machine modifications or misuse.



Exposure to the dust created by power sanding, sawing, grinding, drilling and other construction activities may cause serious and permanent respiratory or other injury, including silicosis (a serious lung disease), cancer, and death. Avoid breathing the dust, and avoid prolonged contact with dust. Some examples of these chemicals are:



- Lead from lead-based paints.
- Crystalline silica from bricks, cement and other masonry products.
- Arsenic and chromium from chemically-treated timber.

Always operate tool in well ventilated area and provide for proper dust removal. Use a dust collection system along with an air filtration system whenever possible. Always use properly fitting approved respiratory protection appropriate for the dust exposure, and wash exposed areas with soap and water.

- ✓ Always wear safety glasses or goggles and protective footwear.
- ✓ Wear dust masks when required.
- ✓ Wear hearing protection that is suitable for the level and frequency of the noise you are exposed to in the woodworking area. If you have trouble hearing someone speak from three feet away, the noise level from the machine may be hazardous.
- ✓ Use gloves to protect hands from splinters when handling wood but do not wear them near rotating blades and other machinery parts where the gloves can catch.

2.1 GENERAL WOODWORKING MACHINE SAFE PRACTICES Cont.

- ✓ Make sure the guard that is in position is in good working condition, and guards the machine adequately before operating any equipment or machine. Check and adjust all other safety devices.
- ✓ Make sure the equipment is properly grounded before use.
- ✓ Check that keys and adjusting wrenches are removed from the machine before turning on the power.
- ✓ Inspect stock for nails or other materials before cutting, planning, routing or carrying out similar activities.
- ✓ Make sure that all machines have start and stop buttons within easy and convenient reach of an operator. Start buttons should be protected so that accidental contact will not start machine.
- ✓ Ensure that all cutting tools and blades are clean, sharp, and in good working order so that they will cut freely, not forced.
- ✓ Turn the power off and unplug the power cord (or lock out the power source) before inspecting, changing, cleaning, adjusting or repairing a blade or a machine. Also turn the power off when discussing the work.
- ✓ Use a “push stick” to push material into the cutting area. Jigs are also useful in keeping hands safe during cutting procedures. Keep hands out of the line of the cutting blade.
- ✓ Always use a push stick for pieces less than 30 cm in length, or for the last 30 cm of a longer cut. Use a push stick to remove the cut piece from between the fence and the blade.
- ✓ Clamp down and secure all work pieces when drilling or milling.
- ✓ Use good lighting so that the work piece, cutting blades, and machine controls can be seen clearly. Position or shade lighting sources so that they do not shine in the operator’s eyes or cause any glare and reflections.
- ✓ Ensure that the floor space around the equipment is sufficient to enable you to machine the size of work piece being processed safely without bumping into other workers or equipment.
- ✓ Woodworking machines should be fitted with efficient and well-maintained local exhaust ventilation systems to remove sawdust or chips that are produced.
- ✓ Electric power cords should be above head level or in the floor in such a way that they are not tripping hazards.
- ✓ Keep work area free of clutter, clean, well swept, and well lit. Spills should be cleaned up immediately. Floor areas should be level and non-slip. Good housekeeping practices and workplace design will reduce the number of injuries and accidents from slips, trips, and falls.
- ✓ Do not wear loose clothing, work gloves, necktie’s, rings, bracelets or other jewellery that can become entangled with moving parts. Confine long hair.
- ✓ Avoid awkward operations and hand positions where a sudden slip could cause your hand to move into the cutting tool or blade.
- ✓ Do not remove sawdust or cuttings from the cutting head by hand while a machine is running. Use a stick or brush when the machine has stopped moving.
- ✓ Do not use compressed air to remove sawdust, turnings, etc. from machines or clothing.
- ✓ Do not leave machines running unattended (unless they are designed and intended to be operated while unattended). Do not leave a machine until the power off is turned off and the machine comes to a complete stop.

2.1 GENERAL WOODWORKING MACHINE SAFE PRACTICES Cont.

- ✓ Do not try to free a stalled blade before turning the power off.
- ✓ Do not distract or startle an operator while he or she is using woodworking equipment.
- ✓ Horseplay should be prohibited. It can lead to injuries.

HAZARDS ASSOCIATED WITH MACHINES include, but are not limited to:

- Being struck by ejected parts of the machinery
- Being struck by material ejected from the machinery
- Contact or entanglement with the machinery
- Contact or entanglement with any material in motion

Health Hazards (other than physical injury caused by moving parts)

- Chemicals hazards that can irritate, burn, or pass through the skin
- Airborne substances that can be inhaled, such as oil mist, metal fumes, solvents, and dust
- Heat, noise, and vibration
- Ionizing or non-ionizing radiation (X-ray, lasers, etc.)
- Biological contamination and waste
- Soft tissue injuries (for example, to the hands, arms, shoulders, back, or neck) resulting from repetitive motion, awkward posture, extended lifting, and pressure grip)

Other Hazards

- Slips and falls from and around machinery during maintenance
- Unstable equipment that is not secured against falling over
- Safe access to/from machines (access, egress)
- Fire or explosion
- Pressure injection injuries from the release of fluids and gases under high pressure
- Electrical Hazards, such as electrocution from faulty or ungrounded electrical components
- Environment in which the machine is used (in a machine shop, or in a work site)



WARNING. Machines are safeguarded to protect the operator from injury or death with the placement of guards. Machines must not be operated with the guards removed or damaged.

2.2 SPECIFIC SAFETY FOR WOOD LATHES

DO NOT use this machine unless you have been instructed in its safe use and operation and have read and understood this manual



Face shield must be worn when operating this machine



Long and loose hair must be contained.



Hearing protection must be worn



Sturdy footwear must be worn at all times in work areas



Close fitting/protective clothing must be worn



Dust masks must be worn when operating this machine.

PRE-OPERATIONAL SAFETY CHECKS

- ✓ Locate and ensure you are familiar with all machine operations and controls.
- ✓ Ensure all guards are fitted, secure and functional. Do not operate if guards are missing or faulty.
- ✓ Check workspaces and walkways to ensure no slip/trip hazards are present.
- ✓ Ensure the workpiece has been suitably prepared for the lathe operation.
- ✓ Workpiece must be securely fastened to face plate, chuck or between centres.
- ✓ Adjust speed to suit the diameter of the work and turning operation.
- ✓ Rotate the workpiece by hand to check clearance between tool rest and bed.
- ✓ Ensure the cutting tools are sharp and in good condition.
- ✓ Start the dust extraction unit before using the machine.

OPERATIONAL SAFETY CHECKS

- ✓ Only one person may operate this machine at any one time.
- ✓ Before making adjustments, switch off and bring the machine to a complete standstill.
- ✓ Keep the tool rest adjusted close to the work and at the correct height.
- ✓ Adjust speed to suit the diameter of the work and turning operation.
- ✓ Stop the lathe and remove all tool rests before sanding.

ENDING OPERATIONS AND CLEANING UP

- ✓ Switch off the machine when work completed.
- ✓ Return all chisels and other tools to racks.
- ✓ Remove all tool-rests and place in rack.
- ✓ Leave the machine in a safe, clean and tidy state.

DON'T

- ✗ Do not use faulty equipment. Immediately report suspect equipment.
- ✗ Never leave the machine running unattended.

POTENTIAL HAZARDS AND INJURIES

- Eye injuries from flying debris or defective timber.
- Hair/clothing getting caught in moving machine parts.
- Airborne dust.

3. POWER SUPPLY

3.1 ELECTRICAL INSTALLATION

Place the machine near an existing power source. Make sure all power cords are protected from traffic, material handling, moisture, chemicals, or other hazards. Make sure there is access to a means of disconnecting the power source. The electrical circuit must meet the requirements for 240V.

NOTE : The use of an extension cord is not recommended as it may decrease the life of electrical components on your machine.

ELECTRICAL REQUIREMENTS

Nominal Voltage.....	240V
Cycle.....	50 Hz
Phase.....	Single Phase
Power Supply Circuit.....	10 Amps
Full Load Current.....	6.8 Amps

(Full load current rating is also on the specification plate on the motor.)

NOTE! *The motor connected to the inverter is 3 phase but the inverter is 240 volt single phase.*

3.2 FULL-LOAD CURRENT RATING

The full-load current rating is the amperage a machine draws when running at 100% of the output power. Where machines have more than one motor, the full load current is the amperage drawn by the largest motor or a total of all the motors and electrical devices that might operate at one time during normal operations.

Full-Load Current Rating for these machine at 240V is 6.8 Amps

It should be noted that the full-load current is not the maximum amount of amps that the machine will draw. If the machine is overloaded, it will draw additional amps beyond the full-load rating and if the machine is overloaded for a long period of time, damage, overheating, or fire may be caused to the motor and circuitry.

This is especially true if connected to an undersized circuit or a long extension lead. To reduce the risk of these hazards, avoid overloading the machine during operation and make sure it is connected to a power supply circuit that meets the requirements.



4 SETUP

4.1 UNPACKING

This machine was carefully packaged for safe transport. When unpacking, separate all enclosed items from packaging materials and inspect them for shipping damage. If items are damaged, please contact your distributor.

NOTE: Save all the packaging materials until you are completely satisfied with the machine and have resolved any issues with the distributor, or the shipping agent.

When unpacking, check the packing list to make sure that all parts shown are included. If any parts are missing or broken, please contact the your distributor.

4.2 CLEAN - UP

The unpainted surfaces of the machine have been coated with a waxy oil to protect them from corrosion during shipment. Remove the protective coating with a solvent cleaner or a citrus based degreaser.

Optimum performance from your machine will be achieved when you clean all moving parts or sliding contact surfaces that are coated with rust prevented products.

It is advised to avoid chlorine based solvents, such as acetone or brake parts cleaner, as they will damage painted surfaces and strip metal should they come in contact. Always follow the manufacturer's instructions when using any type of cleaning product.

4.3 SITE PREPARATION

When selecting the site for the machine, consider the largest size of workpiece that will be processed through the machine and provide enough space around the machine for operating the machine safely. Consideration should be given to the installation of auxiliary equipment. Leave enough space around the machine to open or remove doors/covers as required for the maintenance and service as described in this manual.

It is recommended that the machine is anchored to the floor to prevent tipping or shifting. It also reduces vibration that may occur during operation.

4.4 LIFTING INSTRUCTIONS



WARNING

This machine is extremely heavy.

Serious personal injury may occur if safe moving methods are not followed. To be safe, you will need assistance and power equipment when moving the shipping crate and removing the machine from the crate.



On the day that the machine arrives, make sure that a forklift or lifting device, with sufficient capacity is available to unload the machine from the vehicle. Ensure access to the chosen site is clear and that doors and ceilings are sufficiently high and wide enough to receive the machine.

4.5 ANCHORING TO THE FLOOR

The machine is best mounted on a concrete slab. Masonry anchors with bolts are the best way to anchor machinery, because the anchors sit flush with the floor surface, making it easy to unbolt and move the machine later, if needed. (Fig. 4.1)

Machine Mounting Options

Although it is not required Hafco recommends that you secure your machine to the floor. Masonry anchors with bolts are the best way to anchor machinery, because the anchors sit flush with the floor surface, making it easy to unbolt and move the machine later, if needed. (Fig. 4.2) Other methods of mounting is the use of machine mounts which also help with the levelling of the machine and isolating vibration. (Fig. 4.3)

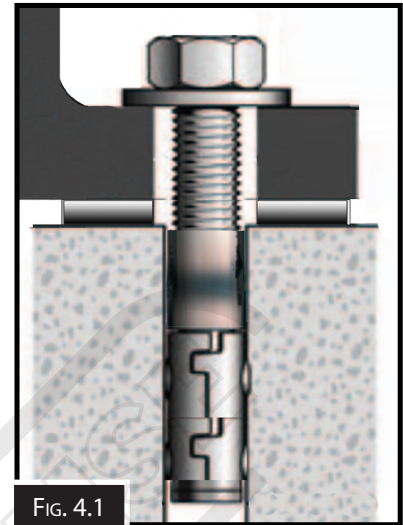

FIG. 4.1



FIG. 4.3



FIG. 4.2

4.6 MACHINE LEVELING

To set your machine up so that it operates to optimum performance, apply the following procedure.

After your machine has been anchored to a concrete slab floor, it then needs to be leveled. Loosen the hold down bolts and place a level on the surface of the working table. Metal shims need to be placed under corner of the base of the machine until level. Once level then tighten the hold down bolts. (Fig. 4.4)

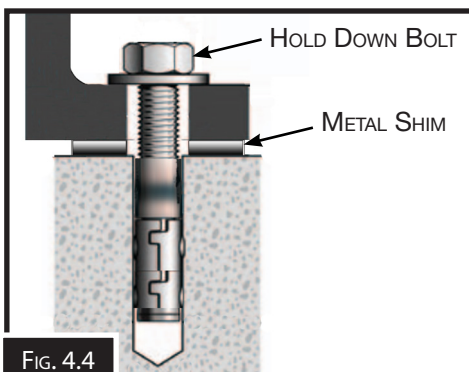

FIG. 4.4

CAUTION

The machine must not rest on supports other than those defined in Fig. 4.4

4.7 ASSEMBLY

The machine must be fully assembled before it can be operated. First clean any parts that are coated in rust preventative to ensure the assembly process can proceed smoothly.

Stand Assembly Instructions

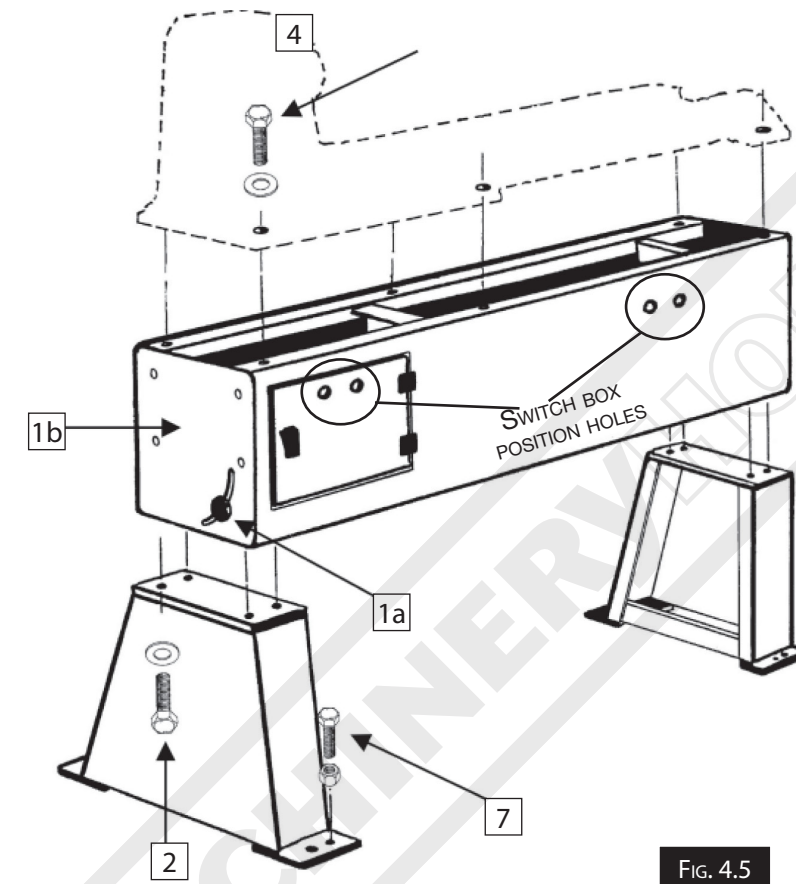

NOTE: See page 14 for best practice assembly instructions.

FIG. 4.5

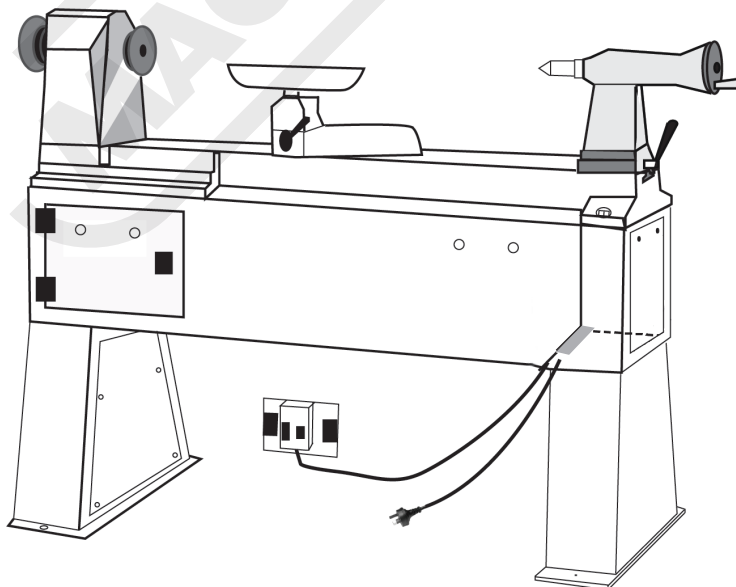

Stand Assembly Instructions

The Hafco Woodmaster WL-52 is very heavy so care must be taken when assembling the machine.

To assemble the machine.

1. Use an eye bolt (not supplied) through the lathe mounting holes and a shackle to attach to the sling. (Fig. 4.6)
2. Once the sling is secure and cannot slip, lift the main channel (1b) from the crate. (Fig. 4.7)
3. Place the main channel onto the legs and attach using 8 off M10 x 30 Set screws, 8 off H/duty M10 washer and 8 off M10 shake proof washer (make sure open side of legs are facing inwards as shown) *** TIGHTEN ALL SCREWS *** (Fig. 4.8)

Note: On assembling main channel onto legs, Note the difference in leg bases. The one with Straight front goes on tailstock end as shown in Figure 4.5.



CAUTION: ENSURE THE SWITCH AND THE CABLE ARE NOT DAMAGED OR CRUSHED WHEN ASSEMBLING THE MACHINE

To secure switch box to switch plate:

4. Secure the remote switch box to the switch plate using 2 off 3/16" x 3/4" countersink screw, 3/16" x 1/2" washer, shake proof washer and hex nut.

Note: The switch box is fitted with a quick release mechanism that allows it to be mounted to the main channel in either of the two sets of 19mm holes. (Fig. 4.10) This allows for easy re-location of the switch at either the headstock end or the tailstock end, placing the switch where best suited for the operated. (For hole positions see Fig. 4.5)



FIG. 4.6



FIG. 4.7



FIG. 4.8

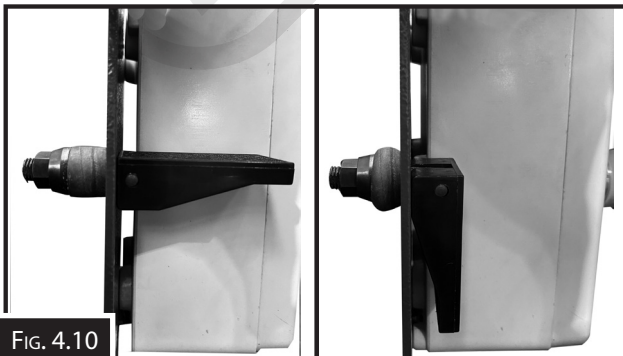

FIG. 4.10



FIG. 4.9

Stand Assembly Instructions

5. Make sure the tailstock has been clamped securely, then place a webbed sling as shown in Fig.4.11. Carefully lift the lathe and place it onto the main channel and attach using the 6 off M10 x 40 Set screws, H/duty M10 washer and M10 shake proof washer.

NOTE: Before you bolting down the lathe, check to see if any gaps appear under any of the 6 bolt holes of the lathe. If there is a gap, it is necessary to pack or shim with a thin washer or piece of steel before final bolting. This will prevent any possible bed distortion, tailstock mis-alignment or incorrect sliding action.

**** TIGHTEN ALL SCREWS *****

6. Move the machine and stand to the position where it will be secured to the floor.
7. Use the 4 of M8 x 25 Set screws in the threaded holes in the feet to stabilize and level the machine, then lock the screws with the 4 xM8 standard nuts before fixing to the floor.

CONNECT THE MOTOR AND SWITCH TO THE POWER

NOTE: Make sure that the power to the machine has been disconnected and the power lead removed from the power point.

After assembling the headstock to the stand and fitting drive multi- V-belt, connect the low voltage plug.(A & B in Fig. 4.12) Then carefully cut the existing cable ties and reposition the connecting plugs as seen in Fig. 4.13. Undo the steel saddle (C in Fig. 4.13) and clamp the cable under the saddle clamp with excess cord to be secured in a loop with a cable tie above the refitted saddle position.

Low voltage plug(B in Fig_4.12) can be pulled down and secured with 2 or 3 cable ties, looping excess cables down the bottom as shown (D in Fig. 4.13) sitting in base of stand out of the way.

Check with Drive belt in Hi speed position (to the Left) that ALL cables are well away from the moving parts of the spindle and multi-V-belt. Also Check saddles securing cords in headstock/bed of lathe are tight.

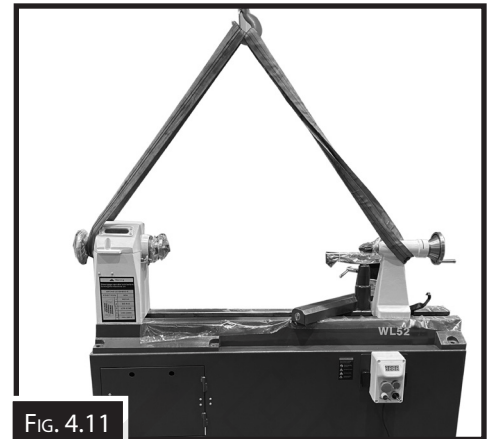

FIG. 4.11

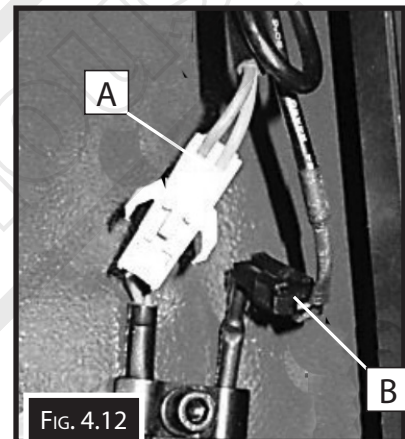

FIG. 4.12

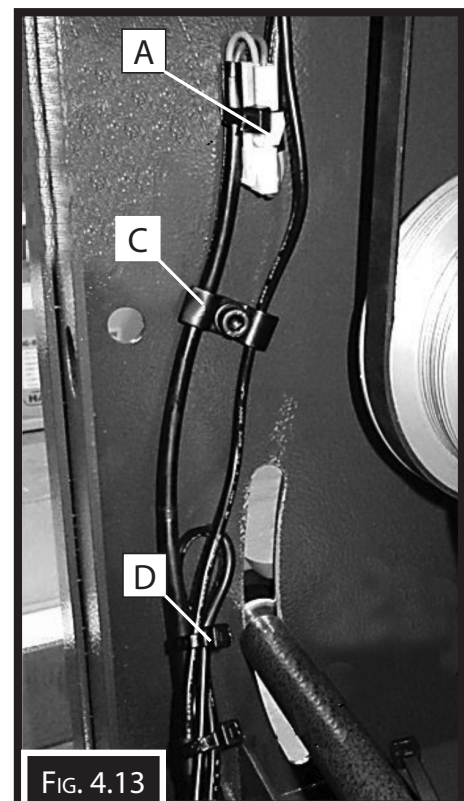

FIG. 4.13

CONNECT THE MOTOR AND SWITCH TO THE POWER

The lathe is supplied as standard with a 240Volt Inverter, and 1.5 kw (2hp) totally enclosed fan cooled motor, a switch with lead and plug for connection to power.

NOTE: If a motor or switch is provided by any other source, then a qualified electrician must be engaged to complete all electrical connections.

Mount the switch to switch plate/stand (refer page 14)

Electronic Variable Speed with Remote Stop / Start Station



WIRING DIAGRAM

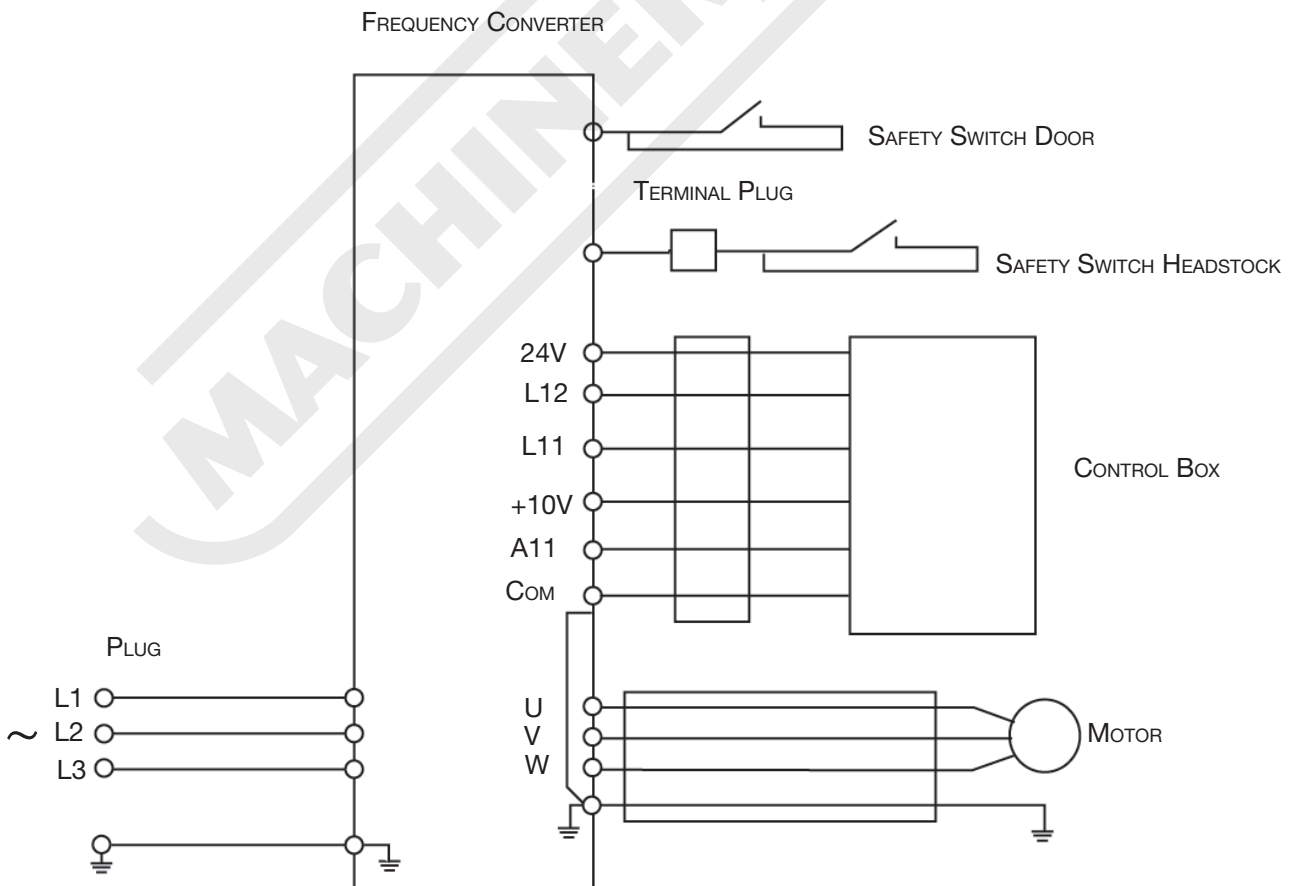

4.8 TEST RUN

Once assembly is complete, test run the machine to ensure it is properly connected to the power and safety components are functioning correctly. Check that the machine rotates in the correct direction. If any problems occur consult Troubleshooting on page 23 or your service engineer.

Testing The Emergency Stop Button

Make sure that the emergency button is working correctly

1. Twist the top of the Emergency Stop button to insure that it is in the raised position.
2. Start the machine and then press the emergency stop button. The machine should stop and the power should be cut off. If the machine cannot be started then the emergency stop is working correctly. To reset the Emergency Stop twist the red top until it pops up.
3. The machine should now work again.



5. OPERATION

This machine may perform many types of operations that are beyond the scope of this manual. Many of these operations may be dangerous or deadly if performed incorrectly.

The instructions in this section are written with the understanding that the operator has the necessary knowledge and skills to operate this machine. If at any time you are experiencing difficulties performing any operation, stop using the machine!

If you are an inexperienced operator, we strongly recommend that you read books, trade articles, or seek training from an experienced operator before performing any unfamiliar operations. Above all, your safety should come first!

5.1 CONTROLS

NOTE: DO NOT start the machine until all of the setup instructions have been performed. Operating a machine that is not setup may result in malfunction or unexpected results that can lead to serious injury, death or damage to the machine or property.

The purpose of this control overview is to provide the novice machine operator with a basic understanding of how the machine is used during operation, and the machine controls and what they do. It also helps the operator to understand if they are discussed later in this manual.

- A. Digital Speed Display :** Displays the speed of the spindle in Revolutions Per Minute
- B. Emergency Stop Button :** When pressed stops all power to the motor and cannot be restarted until the button is reset
- C. Start Button :** Starts the motor and spindle turning
- D. Variable Speed Control :** Adjusts the speed up or down.
- E. Forward & Reverse Switch :** Selects the spindle direction.

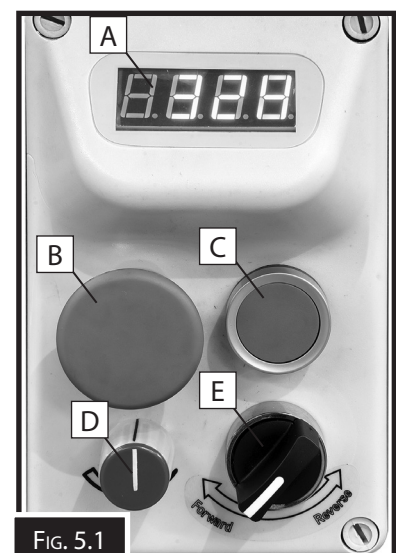

FIG. 5.1

5.2 CHANGING SPEED RANGES

1. The speed of the spindle is controlled in two ways.

A. Belt Position

B. Variable speed within the belt position range.

The chart mounted in front of the headstock indicates the spindle speeds (R.P.M.) relative to the drive belt position.

The 5 convenient spindle speed ranges are available to cover both faceplate and spindle work. The slower speeds are generally used for large and out of balance faceplate work. Faster speeds are used for spindle work especially as the project becomes more slender. Slower speeds are more suited for final sanding work as the less heat generated allows the sanding paper to cut better and also not wear out as quickly.

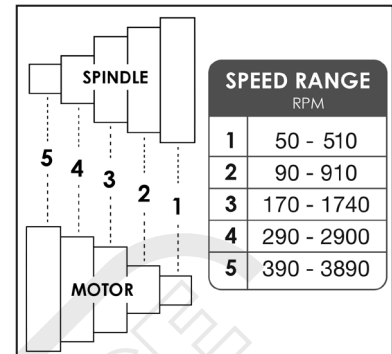

2. To change to a faster or slower speed range, turn off switch and disconnect the machine from the power supply. Open the headstock lid (3), unlock and lift the motor plate assembly. Shift the belt (18) to the required position ensuring the belt (18) is fully seated into the grooves in the pulleys (9 and 59). Lower the motor plate assembly and under its own weight lock the motor lever. Close headstock lid (3).

NOTE: Do not apply excessive load onto the belt (18) prior to locking, as damage may result.

Workpiece Diameter	Suggested Spindle Speeds	
	Roughing	Finishing
Up to 50mm	1000 to 1200 rpm	1900 to 3000 rpm
50mm to 100mm	600 to 700 rpm	1000 to 2300 rpm
100mm to 150mm	600 to 700 rpm	1000 to 1200 rpm
150mm to 300mm	250 to 400 rpm	600 to 700 rpm
300mm to 450mm	250 to 300 rpm	250 to 400 rpm

Suggested spindle speed chart should be used as a guide prior to commencing a new project.

The chart figures were calculated as approximate speeds and suit turners who have completed at least some basic wood turning tuition.

NOTE: Poorly prepared timber blanks that are out of balance can become a hazard therefore slower speeds should be selected.



CAUTION

A prepared list of safety guidelines can never be complete. Every workshop environment is different. Always consider Safety first, as it applies to your individual working conditions. Use this machine and other machinery with caution and respect. Failure to do so could result in serious Personal injury, damage to equipment, or poor work results.

5.3 LATHE PARTS & CONTROLS

B. HEADSTOCK - GENERAL

The headstock (2) supports the main spindle assembly and is rigidly fixed to the bed (1) to ensure long term accuracy and stability. The main spindle (6) is supported by 4 large precision bearings. They are sealed for life and require no lubrication or adjustment during their extended use. These bearings are specially designed to run at high temperatures. Any detection of heat is not necessarily a cause for concern. A failing bearing is usually detected when it becomes noisy, spindle hard to turn or if the spindle is turned slowly by hand and the bearings feel bumpy.

The main spindle (6) is hollow to accept the knock out bar (47) for the removal of tapered centres.



Face plates and chucks should be screwed onto the spindle (6) and up against the hexagon face. Excessive force is not required as it makes for difficult removal. The spindle lock and face plate spanner (46) is used for this purpose.

C. SPINDLE - GENERAL

The spindle is the working part of the lathe. It is mounted with the new **QUATRE PRECISION BEARING SYSTEM**. The 2 directional axial load provides greater performance for both inboard and outboard turning operations.

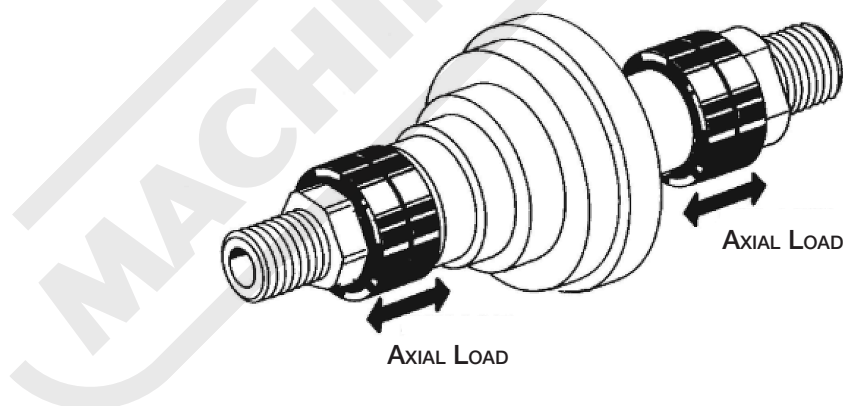

Both ends of the spindle are threaded to allow the attachment of accessories, such as faceplates and chucks. The inboard end of the spindle has a right hand thread and the outboard has a left hand thread. The spindle is also hollow to allow for deep boring and knocking out centres.

The knockout bar (47) provided is for the ease of knocking out centres through the headstock or tailstock.



5. OPERATION

D. FACE PLATE (82 MM 3-1/4")

A face plate can be used by attaching project wooden blanks with wood screws through the 4 holes provided.



E. INDEXING

The dual purpose indexing/spindle lock is positioned at the front of the headstock for ease of use. The headstock pulley (9) has 24 equally spaced holes on its side face. The spring loaded lock pin assembly is engaged by turning the knob half a turn allowing it to drop into the desired hole. To dis-engage, pull the knob (12) forward and turn it half a turn in either direction until the locating pin enters the safety catch position in the knob (12).

The 24 division indexing facility allows accurate pattern work to be carried out on projects such as straight fluting, grooving, drilling, marking out and many more. By adapting a router or electric drill to special purpose fixtures (not supplied), a wide variety of detail can be achieved.

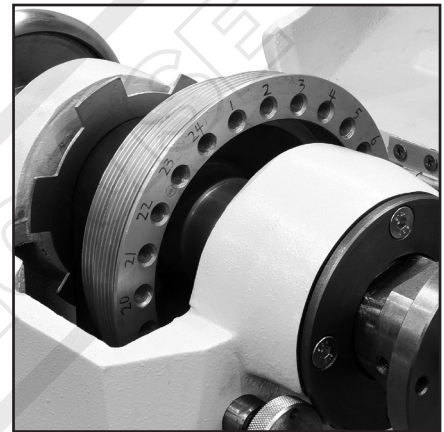

F. SPINDLE LOCK

The spindle lock pin is engaged by choosing any of the spaced holes and is suited for when removing face plates, chucks etc. and also assists the loading of work. When not in use ensure knob is in the safety catch position.

G. SPUR DRIVE CENTRE - HEADSTOCK

1. The spur drive centre (48) is used in conjunction with the revolving centre (50) in the tailstock to support cylindrical work such as chair and table legs, tool handles etc.
2. When loading a project blank onto the spur drive centre, do not use a hammer or similar as damage to the head stock bearings may result. The pressure obtained via the tailstock handwheel (31) should be sufficient to provide adequate drive when using softer woods. For harder woods, shallow diagonal saw cuts in the end section should be made plus a small hole in the centre. The spur centre (48) can now be directly knocked into the wood by using only a soft mallet. Never use a steel hammer as this will damage the taper shank.

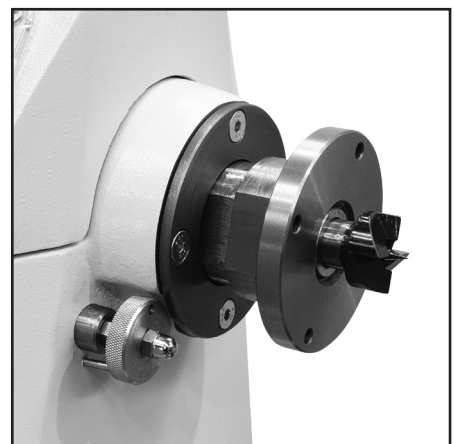

5. OPERATION

H. REVOLVING CUP CENTRE - TAILSTOCK

1. The revolving cup centre is used for supporting spindle turning projects that can not be held suitably in a chuck. It can also be used as a safety device to support face plate work for as long as possible, especially during roughing down stage.



I. CAM-LOCK TOOLREST BRACKET

1. The cam-lock toolrest bracket (39) is designed as a quick action easy to use support base for the toolrest (53 or 54). Locking and unlocking is by way of the cam lever (30) which will operate in either direction. Excessive pressure when locking should be avoided.
2. The toolrest lock screw (45) is positioned for ease of use. Excessive pressure should be avoided.

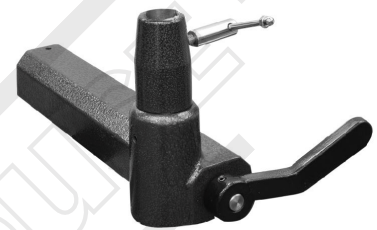

J. TOOLREST

1. The toolrest (53 or 54) has been specially shaped for operator safety and ease of use. The top face has been machined to assist smooth tool movement. If this surface becomes damaged from sharp edged tools, use a fine file to make smooth. (Remove all sharp corners from turning tools such as parting tools and skews).



K. TAILSTOCK

1. The tailstock (22) can be moved along the bed ways and locked by way of the cam lever (30). Excessive pressure should be avoided. The sliding spindle (27) is hollow to allow for long hole drilling as well as having a No.2 morse taper which accepts the revolving support centre (50) and other tapered accessory tools. The spindle (27) is moved by winding the large hand wheel (31) and can be locked when required by the top lever (25).



5.4 WOODTURNING

Faceplate Turning

- A. Check the project blank is free from cracks and defects.
- B. Fix the project blank securely to faceplate with suitable wood screws.
- C. If using a chucking device check that the project blank is well seated before being locked firmly.
- D. Test the project blank is suitably balanced by spinning project by hand.
- E. Always start the lathe on lower speed when first commencing the project.
- F. Have the tailstock supporting the project for as long as possible during turning operation.
- G. Where possible, always cut in a direction towards the headstock. This not only assists the original holding method but provides greater rigidity and longer bearing life.
- H. Ensure cutting tools are correctly sharpened.
- I. Wear adequate safety face shield or glasses when turning.



Spindle Turning

- A. Check project blank is free from cracks and defects.
- B. Hold the project workpiece correctly and securely between centres.
- C. Sufficient force should be applied by the tailstock to safely hold the workpiece when machining. Too much force can damage bearings and cause long slender workpiece to whip in the middle and possibly break.
- D. Rotate the workpiece by hand to ensure it clears the toolrest.
- E. Ensure cutting tools are correctly sharpened.
- F. Wear adequate safety face shield or glasses.
- G. A long slender workpiece may require the use of an additional steady rest.



Deep Boring

- A. Deep boring through a long spindle such as a lamp column requires a special boring cup centre and a boring drill.
- B. Bore the workpiece before the final shaping, in case errors spoil the work.
- C. Guide the boring drill with the left hand through the boring centre and into the work while holding the handle firmly with the right hand.
- D. Choose a speed of approximately 1200 r.p.m. but this will vary depending on the type of wood.
- E. Do not use excessive force when pushing the boring drill into the wood and regularly pull it back to remove the shavings. Too much force may cause the boring drill to drill off line.



WARNING. *Serious injury or death can result from using this machine BEFORE understanding its controls and related safety information. DO NOT operate, or allow others to operate, the machine until the information is understood.*

5.5 TROUBLESHOOTING

If the machine develops a problem, review the trouble shooting section below to find a fix for the problem. If the problem cannot be solved then contact your dealer for help or to book a service engineer.

Symptoms	Possible Cause	Possible Solution
Excessive vibration	Out of balance work	Reduce spindle speed. Prepare wood to a true circle before loading into lathe. Point of holding may not be centralized. Holding method may not be sufficiently tight
	Drive belt has been over tensioned or damaged	Weight of motor should be sufficient prior to locking
	Motor pulley not in correct alignment with headstock pulley.	Re-align motor pulley to headstock pulley square and parallel to each other.
	Headstock pulley loos	Check pulley is correctly on shaft. Tighten L.H. Locknut. Tighten both grub screws in pulley
	Bolts holding motor to support plate are loose	Tighten all bolts and check correct pulley alignment.
	Stand or bench incorrectly standing on floor	Refer to installation instructions
Face plate or chucks running out of true	Dirt build up on rear of faceplate or chucks or around hexagon locking face.	Clean off all build up
Belt not running true or becoming damaged on edges.	Headstock and motor pulley incorrectly lined up	1. Open front door on stand. 2. Loosen 4 motor bolts. 3. Re-align both pulleys square and parallel to each other.
Tailstock		
Tailstock handwheel becoming hard to turn	Build up of dust and wood resin on quill or inside of handwheel thread.	Remove quill and handwheel from tailstock body. Wipe clean all areas including inside of tailstock body lightly oil quill and grease handwheel. Re-assemble
Tailstock not locking correctly onto bed.	Incorrect clamp plate adjustment	By adjusting the nut under the clamp plate increased or decreased clamp pressure can be obtained
Tailstock not running smoothly on bed ways.	Dirty bed ways and underside of tailstock body	Clean bed ways and underside of tailstock body with kerosene or similar.
	Incorrect adjustment on clamp plate	Adjust clamp plate nut
Toolrest		
Turning tools not running smoothly across toolrest	Damaged surface on toolrest face caused by sharp edged tools.	Using a fine file, smooth surface on top of toolrest and polish with sandpaper. Remove sharp edges from corners of turning tools.
Camlock Toolrest Bracket		
Toolrest bracket not locking correctly onto bed.	Incorrect clamp plate adjustment. (Excessive pressure on cam lever should be avoided.)	By adjusting the nut under the clamp plate increased or decreased clamp pressure can be obtained
Toolrest bracket tight to turn	Dirty cam shaft and clamp tube	Remove cam shaft from cam-lock bracket and clean all parts with kerosene or similar

6. MAINTENANCE



Before maintaining or cleaning the machine, turn off the circuit breaker, or disconnect the machine from the power supply. Post a sign to inform other workers that the machine is under maintenance.

For optimum performance from the machine, it is important that the machine is well cleaned and maintain. Follow the maintenance schedule listed in the following section and refer to any specific instructions given.

6.1 SCHEDULE

Daily Check

- Loose mounting bolts.
- Worn or damaged wires.
- Check/adjust lubrication.
- Any other unsafe condition

Weekly Maintenance

- Clean off dust buildup.
- Clean and lubricate lathe bed and tailstock.

Monthly Check

- V-belt tension, damage, or wear.
- Clean/vacuum dust buildup from inside cabinet and off motor.

Annually

- Re-check the bedways for being level side-to-side and front-to-back.
- Check all electrical plugs and leads for damage and replace if necessary.



WARNING. Before operating any machine, take time to read and understand all safety signs and symbols. If not understood seek explanation from your supervisor.



WARNING!

*Electricity is dangerous and could cause death
All electrical work must be carried out by a qualified electrician.*

6. MAINTENANCE Cont.

6.2 LUBRICATING AND CLEANING

All parts of your lathe should be cleaned or lubricated after use with special attention to the points below.

1. Bed Ways

Occasionally wipe clean with kerosene or similar.

2. Tailstock Spindle

Wipe clean and lightly oil to maintain smooth travel.

3. Toolrest Bracket

Clean the cam shaft (42), the clamp tube (43) and the clamp block (23) for ease of movement.

4. Main Spindle

Keep the thread clean and especially the back locating face. Any build-up of dirt or damage to this area will affect the true running of face plates, chucks etc.

5. Avoid Rust

The morse taper in both the headstock spindle (6) and the tailstock spindle (27) can become rusted caused by moisture from the wood being turned or from the air especially if the lathe is not being used regularly.

Occasionally smear a little oil into the tapers but it must be wiped dry before inserting any of the centres to avoid slippage.

6. Indexing / Spindle Lock

If needed add a few drops of oil to plunger pin assembly.

Note: The 4 large precision bearings are sealed for life and require no lubrication or adjustment during their extended use.

6.3 BELT ADJUSTMENT

To ensure optimal power transmission from the motor to the spindle, the belt must be in good condition and properly tensioned. The belt should be checked for cracks, fraying and wear. Check belt tension every three months; more often if the machine is used frequently.

The Check The Belt

1. DISCONNECT LATHE FROM POWER!
2. Open the cabinet door.
3. Push the center of the belt. It should feel rigid to the touch with almost no deflection or play.
 - If there is deflection in the belt, then tension the belt.
 - If the belt is cracked, frayed or glazed, it should be replaced immediately.

SPARE PARTS SECTION

HOW TO ORDER SPARE PARTS

1. Have your machines model number, serial number & date of manufacture on hand, these can be found on the specification plate mounted on the machine

NOTE: SOME PARTS MAY ONLY BE AVAILABLE AS AN ASSEMBLY

2. Go to www.machineryhouse.com.au/contactus and fill out the inquiry form

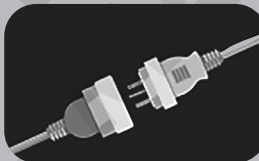

WARNING

Always disconnect the power to the machine before servicing or doing maintenance to the machine.

PARTS DIAGRAM

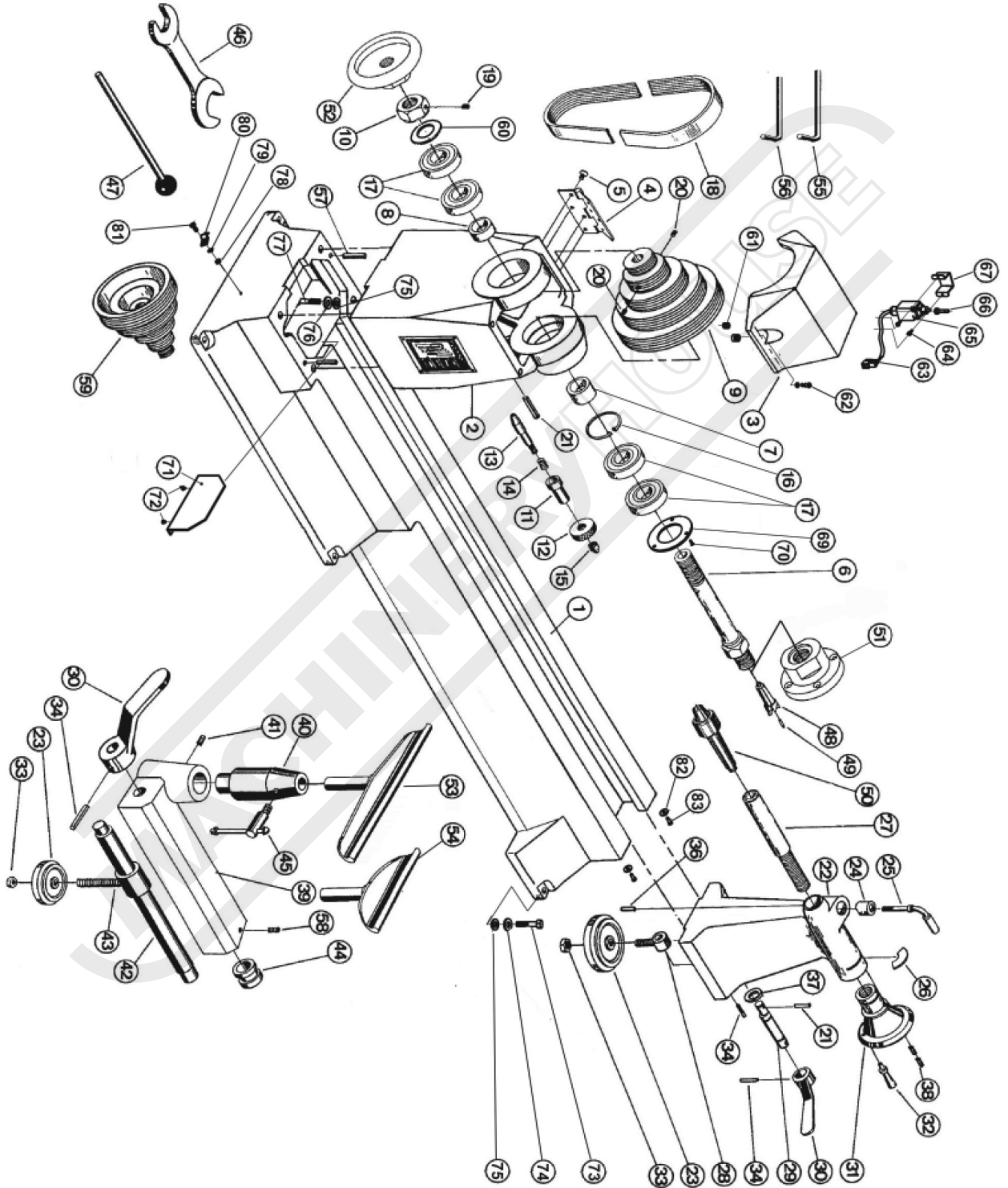

PARTS LIST

Item	DESCRIPTION	Item	DESCRIPTION
1	Lathe bed	43	Cam bolt assembly
2	Headstock	44	Bush - c/lock bracket
3	Headstock lid	45	Lock screw assembly
4	Hinge - Headstock lid	46	Spanner - double ended
5	Screw - gutter bolt 6mm x 8mm long	47	Knockout bar assembly
6	Main spindle - 33mm x 3.5p	48	Spur drive centre - 25mm
7	Spacer 35mm	49	Centre point
8	Spacer 14mm	50	Revolving cup centre
9	Pulley - headstock	51	82mm Face plate R/H - 33mm x 3.5p
10	Lock collar - 33mm x 3.5p	52	Handwheel brake 33mm x 3.5 L.H.
11	Body - index pin	53	Toolrest 300mm
12	Nut - index pin	54	Toolrest 150mm
13	Pin - index pin	55	Allen key 4.0mm
14	Spring - index pin	56	Allen key 3.0mm
15	Dome nut 6mm	57	Sellok pin 8mm x 25mm long
16	Circlip 62mm J62	58	Grub screw M8 x 16
17	Bearing - 6007 VVCM	59	Motor pulley 19mm bore
18	Poly vee belt 550-J6	60	Washer
19	Grub screw M8 x 8	61	Spring
20	Grub screw M8 x 16	62	Oval Phillips Head 1/4 turn stud
21	Sellok pin 3mm x 26mm long	63	Plug B Assembly
22	Tailstock body	64	Screw M4x12
23	Clamp disc	65	Safety Switch
24	Clamp block	66	Pin - Safety Switch
25	Clamp screw	67	Bracket - Safety Switch
26	Keeper plate	69	Retaining plate
27	Spindle - tailstock	70	Screw M6x12
28	Cam bolt- tailstock	71	Insert Plate
29	Cam spindle - tailstock	72	Rivet 3x6
30	Lock handle	73	Hex. Head Bolt M10x40
31	Handwheel - tailstock	74	Washer
32	Handle - handwheel	75	Int. Teeth Lock Washer M10
33	Nyloc nut M12	76	Flat Washer M10
34	Sellok pin 5mm x 40mm long	77	Hex. Head Bolt M10x30
36	Screw M6x12	78	Nut M4
37	Washer Heavy duty 12mm	79	Washer M4
38	Grub screw M6 x 8	80	Clamp - Plug
39	Toolrest bracket - body	81	Screw 4x15
40	Insert	82	Washer M5
41	Grub screw M8 x 12	83	Screw M6x8
42	Spindle - cam-lock bracket		

NOTE: SOME INDIVIDUAL PARTS MAY ONLY BE AVAILABLE AS AN ASSEMBLY

WARNING

General Machinery Safety Instructions

Machinery House
requires you to read this entire Manual before using this machine.

- 1. Read the entire Manual before starting machinery.** Machinery may cause serious injury if not correctly used.
- 2. Always use correct hearing protection when operating machinery.** Machinery noise may cause permanent hearing damage.
- 3. Machinery must never be used when tired, or under the influence of drugs or alcohol.** When running machinery you must be alert at all times.
- 4. Wear correct Clothing.** At all times remove all loose clothing, necklaces, rings, jewelry, etc. Long hair must be contained in a hair net. Non-slip protective footwear must be worn.
- 5. Always wear correct respirators around fumes or dust when operating machinery.** Machinery fumes & dust can cause serious respiratory illness. Dust extractors must be used where applicable.
- 6. Always wear correct safety glasses.** When machining you must use the correct eye protection to prevent injuring your eyes.
- 7. Keep work clean and make sure you have good lighting.** Cluttered and dark shadows may cause accidents.
- 8. Personnel must be properly trained or well supervised when operating machinery.** Make sure you have clear and safe understanding of the machine you are operating.
- 9. Keep children and visitors away.** Make sure children and visitors are at a safe distance for you work area.
- 10. Keep your workshop childproof.** Use padlocks, Turn off master power switches and remove start switch keys.
- 11. Never leave machine unattended.** Turn power off and wait till machine has come to a complete stop before leaving the machine unattended.
- 12. Make a safe working environment.** Do not use machine in a damp, wet area, or where flammable or noxious fumes may exist.
- 13. Disconnect main power before service machine.** Make sure power switch is in the off position before re-connecting.
- 14. Use correct amperage extension cords.** Undersized extension cords overheat and lose power. Replace extension cords if they become damaged.
- 15. Keep machine well maintained.** Keep blades sharp and clean for best and safest performance. Follow instructions when lubricating and changing accessories.
- 16. Keep machine well guarded.** Make sure guards on machine are in place and are all working correctly.
- 17. Do not overreach.** Keep proper footing and balance at all times.
- 18. Secure workpiece.** Use clamps or a vice to hold the workpiece where practical. Keeping the workpiece secure will free up your hand to operate the machine and will protect hand from injury.
- 19. Check machine over before operating.** Check machine for damaged parts, loose bolts, Keys and wrenches left on machine and any other conditions that may effect the machines operation. Repair and replace damaged parts.
- 20. Use recommended accessories.** Refer to instruction manual or ask correct service officer when using accessories. The use of improper accessories may cause the risk of injury.
- 21. Do not force machinery.** Work at the speed and capacity at which the machine or accessory was designed.
- 22. Use correct lifting practice.** Always use the correct lifting methods when using machinery. Incorrect lifting methods can cause serious injury.
- 23. Lock mobile bases.** Make sure any mobile bases are locked before using machine.
- 24. Allergic reactions.** Certain metal shavings and cutting fluids may cause an allergic reaction in people and animals, especially when cutting as the fumes can be inhaled. Make sure you know what type of metal and cutting fluid you will be exposed to and how to avoid contamination.
- 25. Call for help.** If at any time you experience difficulties, stop the machine and call you nearest branch service department for help.

WARNING

Wood Lathe Safety Instructions

Machinery House
requires you to read this entire Manual before using this machine.

- 1. Maintenance/Adjustments.** Make sure the lathe is turned off and disconnect from the main power supply and make sure all moving parts have come to a complete stop before any inspection, adjustment or maintenance is carried out.
- 2. Lathe Condition.** Lathe must be maintained for a proper working condition. Never operate a lathe that has damaged or worn parts. Scheduled routine maintenance should be performed on a scheduled basis.
- 3. Leaving a Lathe Unattended.** Always shut the lathe off and make sure all moving parts have come to a complete stop before leaving the lathe. An unsupervised running lathe can cause serious injury.
- 4. Avoiding Entanglement.** Remove loose clothing, belts, or jewelry items. Tie up long hair and use the correct hair nets to avoid any entanglement with moving parts.
- 5. Guards safety.** Make sure all guards supplied are in good condition and in place. Make sure the lathe sits on a flat stable surface.
- 6. Eye and Face protection.** Always wear eye protection and a face shield when operating the lathe.
- 7. Respiratory protection.** Always wear a respirator when using the machine. Wood dust may cause allergies or long term respiratory health problems.
- 8. Mounting the workpiece.** Make sure the workpiece is properly embedded on the headstock and tailstock centres. A loose workpiece can be thrown across the room and cause serious injury to you or a by-stander.
- 9. Workpiece clearance.** Rotate the workpiece by hand to check for adequate clearance before turning the lathe on.
- 10. Stopping the lathe.** Do not slow or stop the lathe chuck by using your hand against the workpiece. Allow the lathe to stop on its own.
- 11. Avoiding Entanglement.** Remove loose clothing, belts, or jewelry items. Never wear gloves while machine is in operation. Tie up long hair and use the correct hair nets to avoid any entanglement with moving parts.
- 12. Workpiece condition.** Always inspect the workpiece condition. Check for knots, splits, nails, and any other potentially dangerous conditions. Make sure joints of glued-up pieces have high quality bonds and won't fly apart during operation.
- 13. Adjusting tool rest height.** Always adjust the tool rest to the correct height to provide proper support for the turning tool you will be using. Test the clearance between the tool rest and the workpiece by rotating the workpiece by hand before turning the lathe on.
- 14. Speed selection.** Select the appropriate speed for the type of work, material, and tool bit. Allow the lathe to reach full speed before using.
- 15. Use sharp Chisels.** Keep lathe chisels properly sharpened and held firmly in position when using.
- 16. Faceplate Turning.** When faceplate turning, use lathe chisels on the downward spinning side of the workpiece only.
- 17. Sanding/Polishing.** Remove the tool rest when performing sanding or polishing operations on the rotating spindle.
- 18. Material removal rate.** Removing too much material at once may cause the workpiece to fly out of the lathe.
- 19. Workpiece Vibration.** If the workpiece vibrates, turn off the machine immediately. Check to make sure the workpiece is centered and balanced. Trim excess waste off the corners with a bandsaw or table saw to reduce vibration. Make sure the workpiece is securely attached in setup.
- 20. Power outage.** In the event of a power failure during use of the lathe, turn off all switches to avoid possible sudden start up once power is restored.
- 21. Clean work area.** Keep the area around the lathe clean from oil, tools and chips.
- 22. Call for help.** If at any time you experience difficulties, stop the machine and call your nearest branch service department for help.

PLANT SAFETY PROGRAM

NEW MACHINERY HAZARD IDENTIFICATION, ASSESSMENT & CONTROL

Wood Lathe

Developed in Co-operation Between A.W.I.S.A and Australia Chamber of Manufactures
 This program is based upon the Safe Work Australia, Code of Practice - Managing Risks of Plant in the Workplace (WHSA 2011 No10)



Item No.	Hazard Identification	Hazard Assessment	Risk Control Strategies (Recommended for Purchase / Buyer / User)
A	ENTANGLEMENT	HIGH	Eliminate, avoid loose clothing / Long hair etc.
C	CUTTING, STABBING, PUNCTURING	MEDIUM	Isolate power to machine prior to any checks or maintenance. Do not open or clean inside until the machine has completely stopped.
D	SHEARING	MEDIUM	Make sure all guards are secured shut when machine is on.
F	STRIKING	MEDIUM	Ensure workpiece is secured and toolrests are locked tight in correct position. A face mask must be worn at all times. Secure and support heavy material. Remove all loose objects around moving parts.
H	ELECTRICAL	MEDIUM	Ensure spindle is in the correct direction before machining. All electrical enclosures should only be opened with a tool that is not to be kept with the machine.
O	OTHER HAZARDS, NOISE, DUST.	LOW	Wear hearing protection as required. Must be connected to dust extraction
Plant Safety Program to be read in conjunction with manufactures instructions			



www.machineryhouse.com.au



www.machineryhouse.co.nz

Authorised and signed by: 
 Safety officer:
 Manager: 

Revised Date: 12th March 2012